

## 150V N-Ch Power MOSFET

### Feature

- ◇ Optimized for high speed smooth switching, Logic level
- ◇ Enhanced Body diode dv/dt capability
- ◇ Enhanced Avalanche Ruggedness
- ◇ 100% UIS Tested, 100% Rg Tested

### Application

- ◇ DC-DC Conversion
- ◇ Hard Switching and High Speed Circuit
- ◇ Power Tools
- ◇ UPS
- ◇ SSR

$V_{DS}$		150	V
$R_{DS(on),typ}$	$V_{GS}=10V$	16.0	m $\Omega$
$R_{DS(on),typ}$	$V_{GS}=4.5V$	19	m $\Omega$
$I_D$ (Silicon Limited)		69	A

TO-252

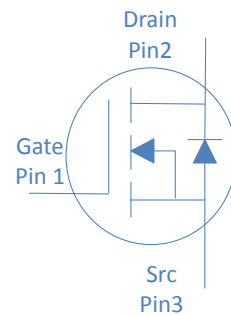
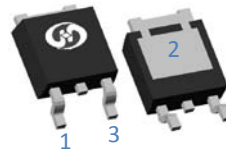

Part Number	Package	Marking
HGD190N15SL	TO-252	GD190N15SL

### Absolute Maximum Ratings at $T_j=25^\circ\text{C}$ (unless otherwise specified)

Parameter	Symbol	Conditions	Value	Unit
Continuous Drain Current (Silicon Limited)	$I_D$	$T_C=25^\circ\text{C}$	69	A
		$T_C=100^\circ\text{C}$	49	
Drain to Source Voltage	$V_{DS}$	-	150	V
Gate to Source Voltage	$V_{GS}$	-	$\pm 20$	V
Pulsed Drain Current	$I_{DM}$	-	150	A
Avalanche Energy, Single Pulse	$E_{AS}$	$L=0.3\text{mH}, T_C=25^\circ\text{C}$	184	mJ
Power Dissipation	$P_D$	$T_C=25^\circ\text{C}$	188	W
Operating and Storage Temperature	$T_J, T_{stg}$	-	-55 to 175	$^\circ\text{C}$

### Absolute Maximum Ratings

Parameter	Symbol	Max	Unit
Thermal Resistance Junction-Case	$R_{\theta JC}$	0.8	$^\circ\text{C/W}$
Thermal Resistance Junction-Ambient	$R_{\theta JA}$	50	$^\circ\text{C/W}$

## Electrical Characteristics at $T_J=25^{\circ}\text{C}$ (unless otherwise specified)

### Static Characteristics

Parameter	Symbol	Conditions	Value			Unit
			min	typ	max	
Drain to Source Breakdown Voltage	$V_{(BR)DSS}$	$V_{GS}=0V, I_D=250\mu A$	150	-	-	V
Gate Threshold Voltage	$V_{GS(th)}$	$V_{GS}=V_{DS}, I_D=250\mu A$	1	1.7	3	
Zero Gate Voltage Drain Current	$I_{DSS}$	$V_{GS}=0V, V_{DS}=150V, T_J=25^{\circ}\text{C}$	-	-	1	$\mu A$
		$V_{GS}=0V, V_{DS}=150V, T_J=100^{\circ}\text{C}$	-	-	100	
Gate to Source Leakage Current	$I_{GSS}$	$V_{GS}=\pm 20V, V_{DS}=0V$	-	-	$\pm 100$	nA
Drain to Source on Resistance	$R_{DS(on)}$	$V_{GS}=10V, I_D=20A$	-	16	19	$m\Omega$
		$V_{GS}=4.5V, I_D=20A$	-	19	25	$m\Omega$
Transconductance	$g_{fs}$	$V_{DS}=5V, I_D=20A$	-	53	-	S
Gate Resistance	$R_G$	$V_{GS}=0V, V_{DS}$ Open, $f=1\text{MHz}$	-	3.5	-	$\Omega$

### Dynamic Characteristics

Input Capacitance	$C_{iss}$	$V_{GS}=0V, V_{DS}=75V, f=1\text{MHz}$	-	2300	-	pF
Output Capacitance	$C_{oss}$		-	158	-	
Reverse Transfer Capacitance	$C_{rss}$		-	6	-	
Total Gate Charge	$Q_g(10V)$	$V_{DD}=75V, I_D=20A, V_{GS}=10V$	-	30	-	nC
Total Gate Charge	$Q_g(4.5V)$		-	13.5	-	
Gate to Source Charge	$Q_{gs}$		-	6.5	-	
Gate to Drain (Miller) Charge	$Q_{gd}$		-	3.5	-	
Turn on Delay Time	$t_{d(on)}$	$V_{DD}=75V, I_D=20A, V_{GS}=10V,$ $R_G=10\Omega,$	-	13	-	ns
Rise time	$t_r$		-	4	-	
Turn off Delay Time	$t_{d(off)}$		-	26	-	
Fall Time	$t_f$		-	6	-	

### Reverse Diode Characteristics

Diode Forward Voltage	$V_{SD}$	$V_{GS}=0V, I_F=20A$	-	0.9	1.2	V
Reverse Recovery Time	$t_{rr}$	$V_R=75V, I_F=20A, di_F/dt=100A/\mu s$	-	90	-	ns
Reverse Recovery Charge	$Q_{rr}$		-	270	-	nC

Fig 1. Typical Output Characteristics

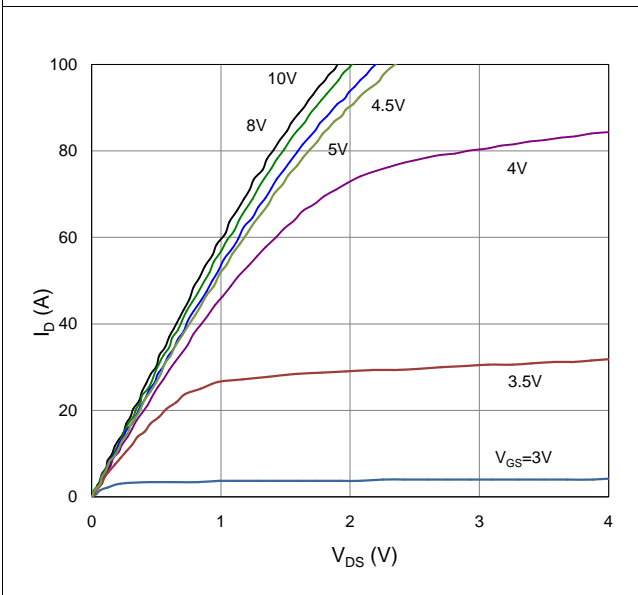

Figure 2. On-Resistance vs. Gate-Source Voltage

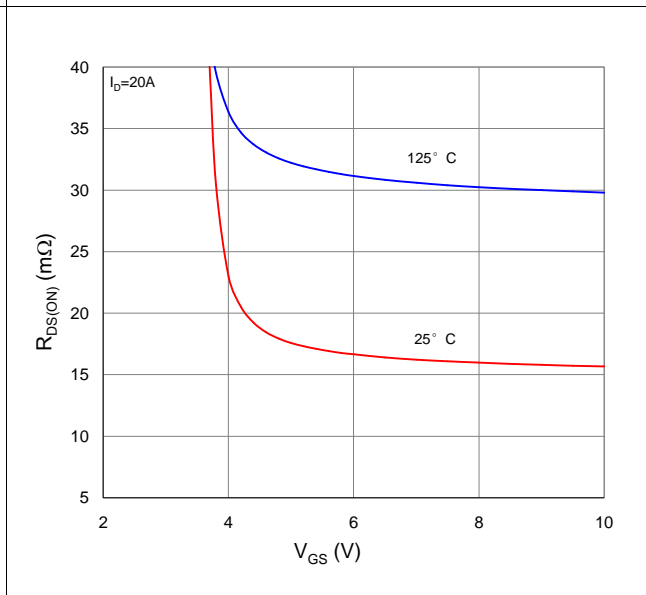

Figure 3. On-Resistance vs. Drain Current and Gate Voltage

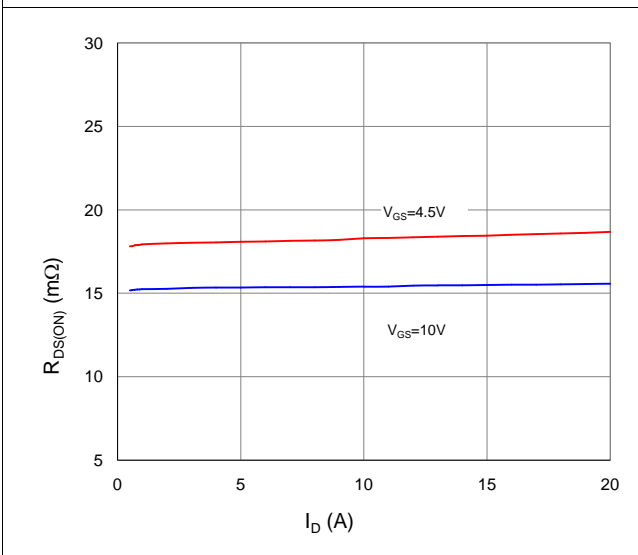

Figure 4. Normalized On-Resistance vs. Junction Temperature

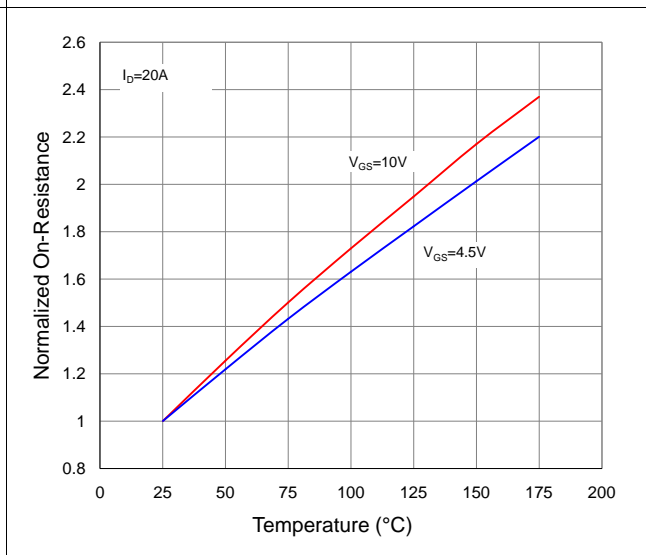

Figure 5. Typical Transfer Characteristics

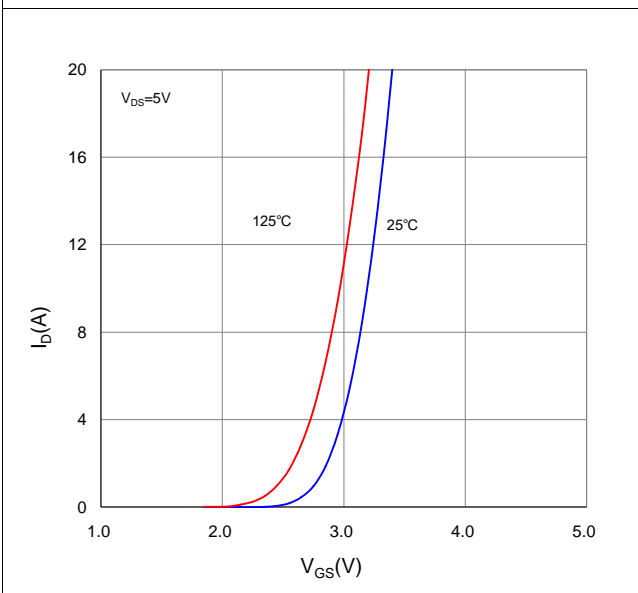

Figure 6. Typical Source-Drain Diode Forward Voltage

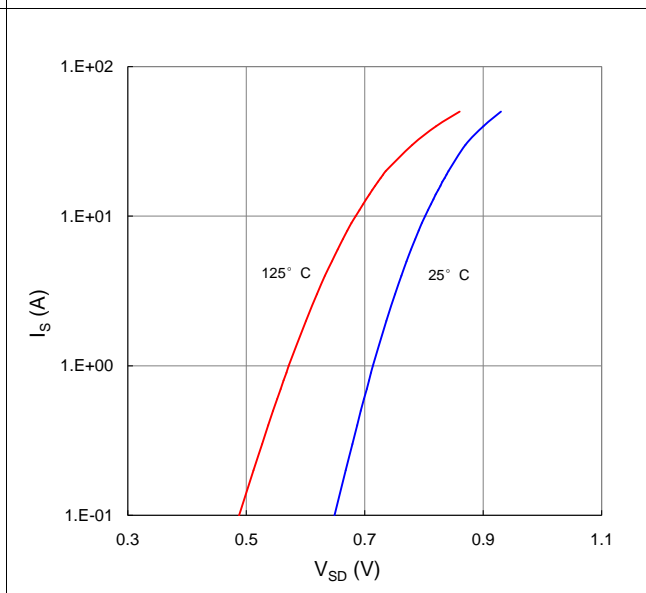

Figure 7. Typical Gate-Charge vs. Gate-to-Source Voltage

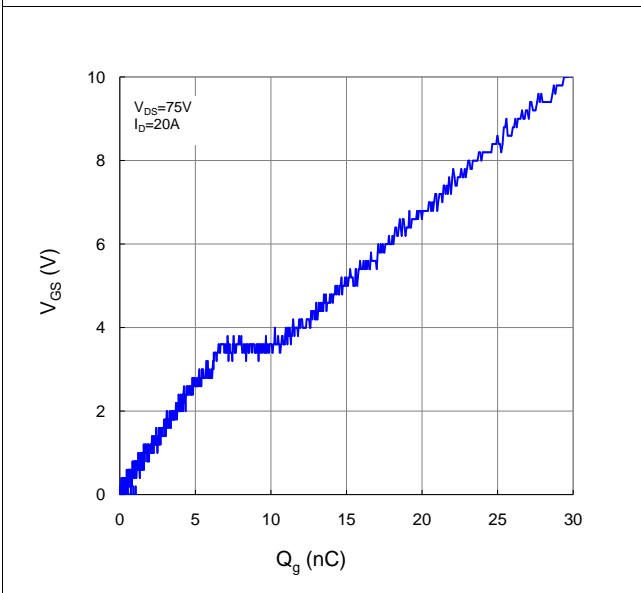

Figure 8. Typical Capacitance vs. Drain-to-Source Voltage

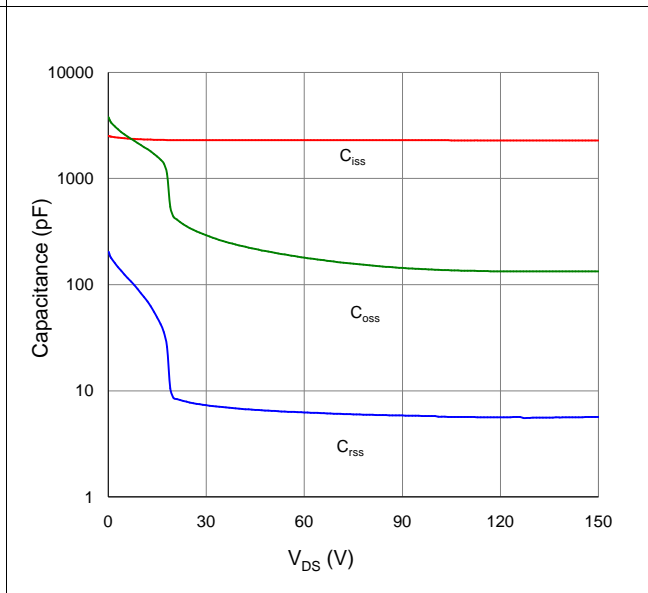

Figure 9. Maximum Safe Operating Area

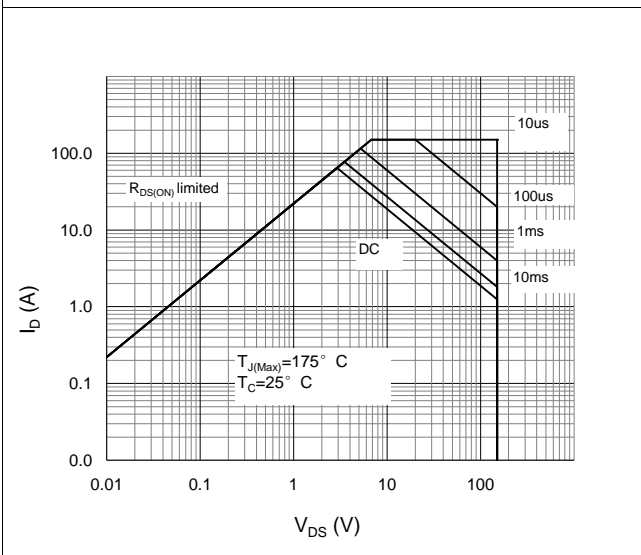

Figure 10. Maximum Drain Current vs. Case Temperature

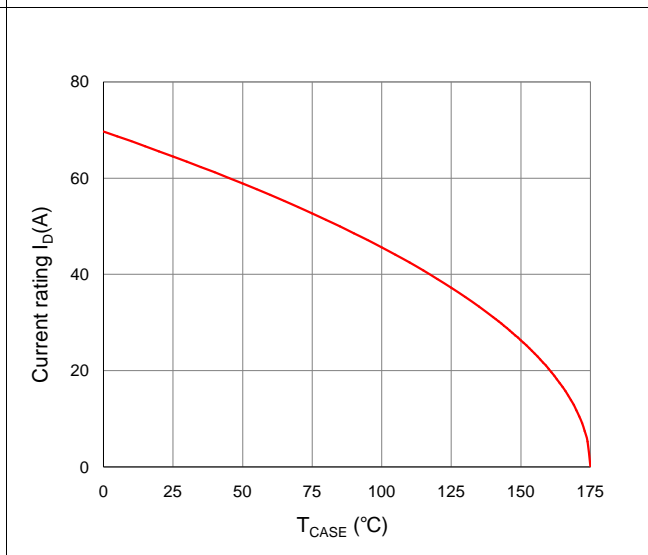
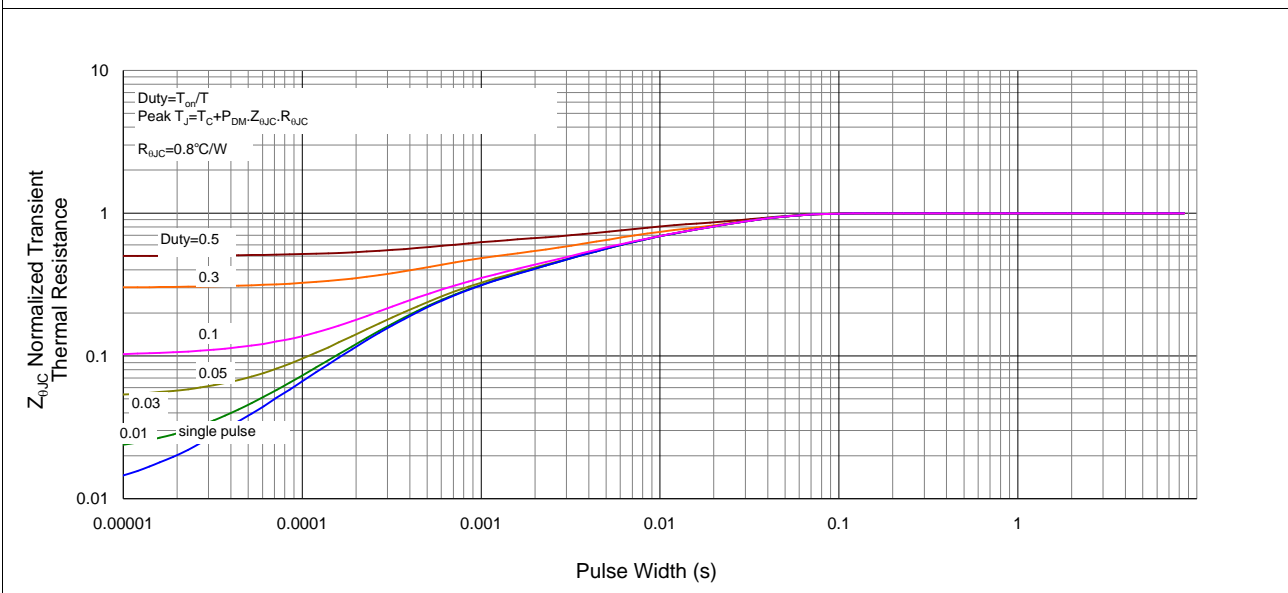
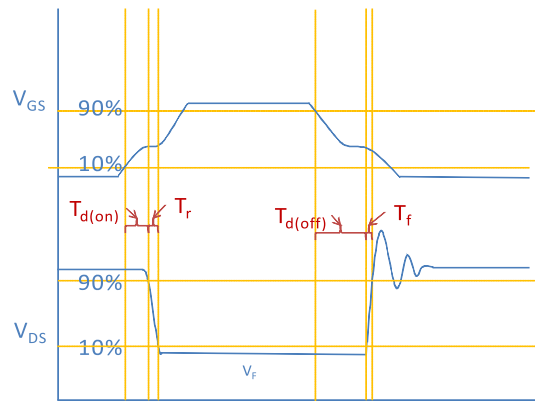
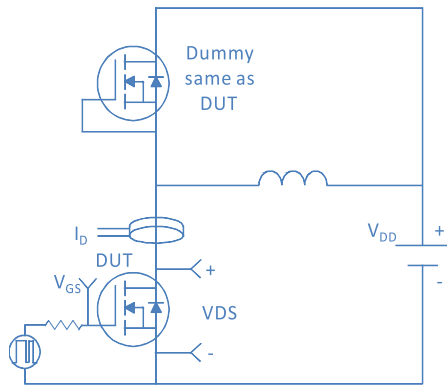

Figure 11. Normalized Maximum Transient Thermal Impedance, Junction-to-Case



## Inductive switching Test



## Gate Charge Test

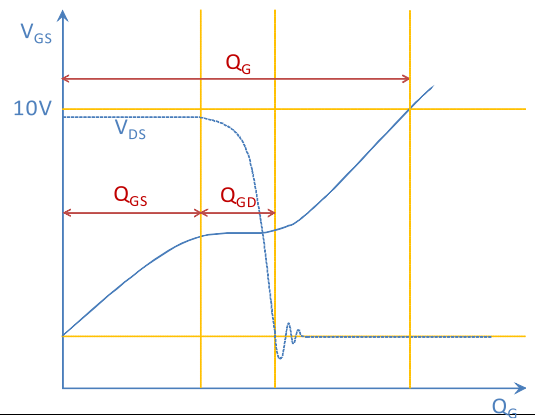

## Uclamped Inductive Switching (UIS) Test

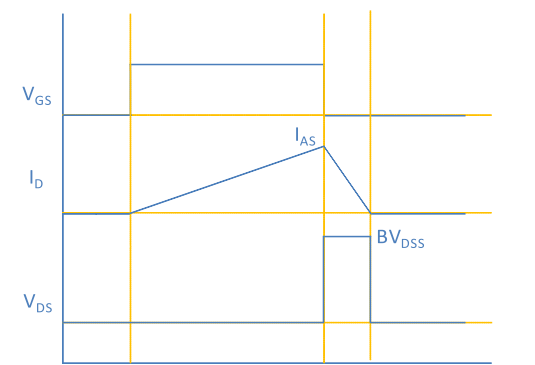
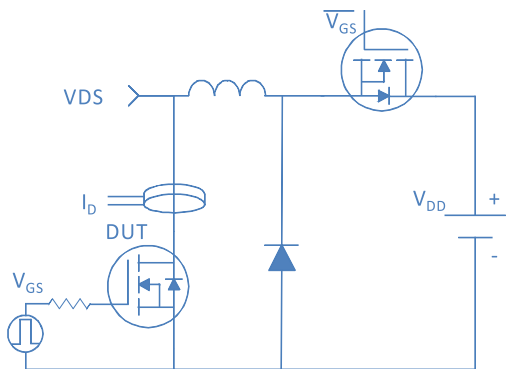

## Diode Recovery Test

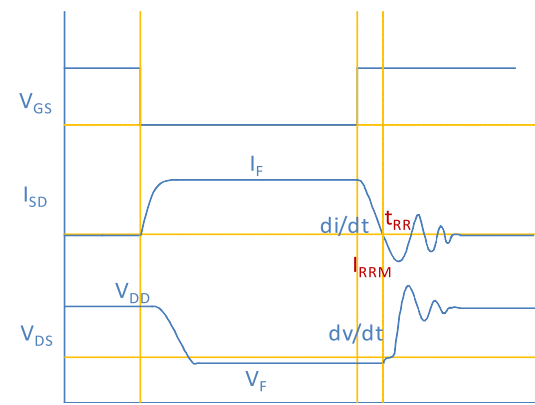

## Package Outline

### TO-252, 2 leads

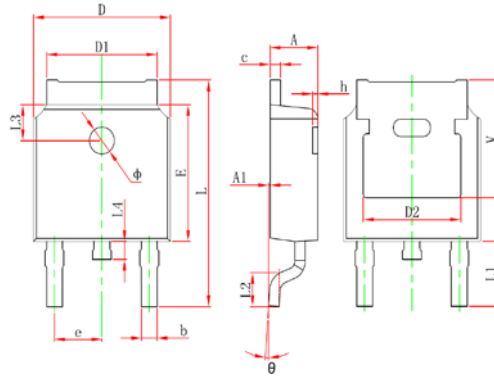

Symbol	Dimensions In Millimeters		Dimensions In Inches	
	Min.	Max.	Min.	Max.
A	2.200	2.400	0.087	0.094
A1	0.000	0.127	0.000	0.005
b	0.660	0.860	0.026	0.034
c	0.460	0.580	0.018	0.023
D	6.500	6.700	0.256	0.264
D1	5.100	5.460	0.201	0.215
D2	4.830 REF.		0.190 REF.	
E	6.000	6.200	0.236	0.244
e	2.186	2.386	0.086	0.094
L	9.800	10.400	0.386	0.409
L1	2.900 REF.		0.114 REF.	
L2	1.400	1.700	0.055	0.067
L3	1.600 REF.		0.063 REF.	
L4	0.600	1.000	0.024	0.039
Φ	1.100	1.300	0.043	0.051
θ	0°	8°	0°	8°
h	0.000	0.300	0.000	0.012
V	5.350 REF.		0.211 REF.	